

Note that all unique customer requirements (i.e tolerance) need to be verified thru Alfa Laval.

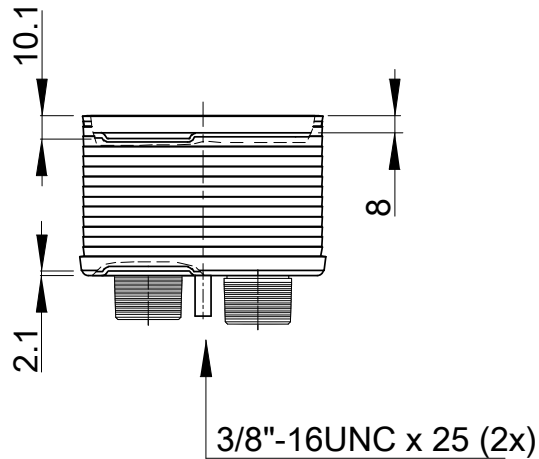
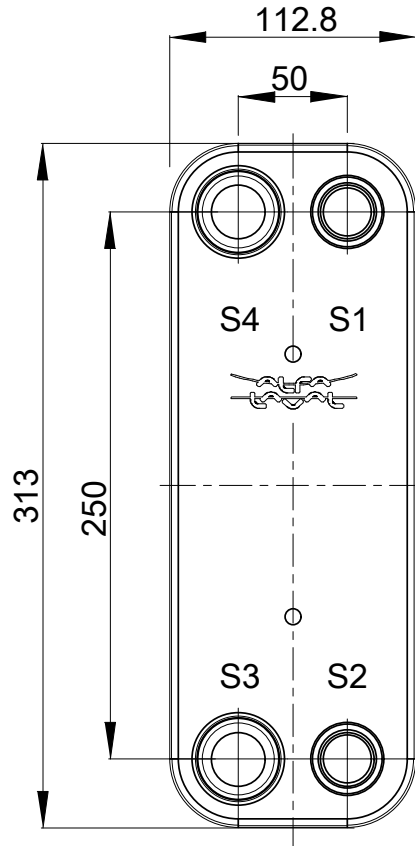
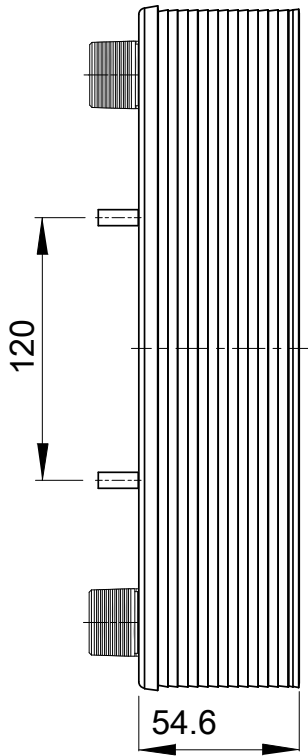
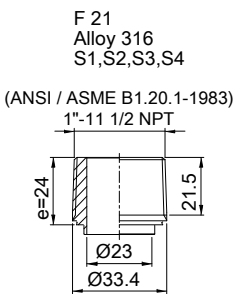

HEATING SURFACE
NETWEIGHT 3.99 kg
OPERATING WEIGHT
PLATE MATERIAL Alloy 316
PLATE GROUPING 1*8L/1*9L

T1 T2 T3 T4 locations on back side correspond to S1 S2 S3 S4 on front side

ALL DIMENSIONS IN MILLIMETERS

SIDE	MEDIA	INLET	TEMP.	OUTLET	TEMP.	FLOW RATE	PRESSURE DROP	LIQUID VOL.
1								0.43 dm³
2								0.49 dm³

PRESSURE VESSEL APPROVAL

UL/CRN

CB30-18L T06 (3287099366)

www.alfalaval.com

CUSTOMER NAME / REF. NO.

TOTAL LENGTH 80.6 mm
TOTAL WIDTH 113.0 mm
TOTAL HEIGHT 313.0 mm

COMPANY / REF.

8/24/2017
REV 0